

# JVC

# SERVICE MANUAL

## CD RECEIVER

# KD-S576

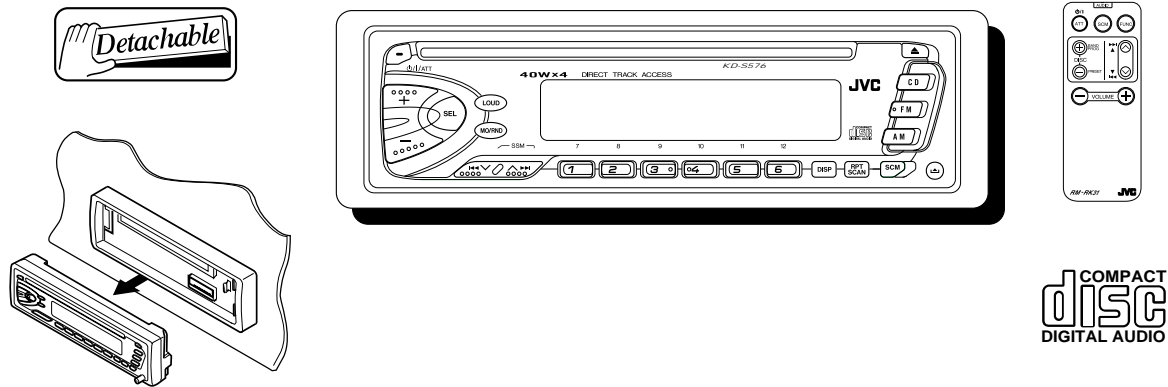



**Area Suffix**  
 J ..... Northern America  
 (Paraguay)

### Contents

Safety precaution .....	1-2
Location of main parts .....	1-3
Disassembly method .....	1-4
Adjustment method .....	1-9
Flow of functional operation until TOC read .....	1-10
Maintenance of laser pickup .....	1-12
Replacement of laser pickup .....	1-12
Description of major ICs .....	1-13

## Safety precaution

 **CAUTION** Burrs formed during molding may be left over on some parts of the chassis. Therefore, pay attention to such burrs in the case of performing repair of this system.

 **CAUTION** Please use enough caution not to see the beam directly or touch it in case of an adjustment or operation check.

# Location of main parts

## ■ Control unit

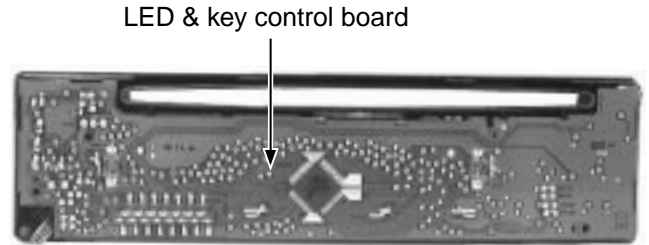
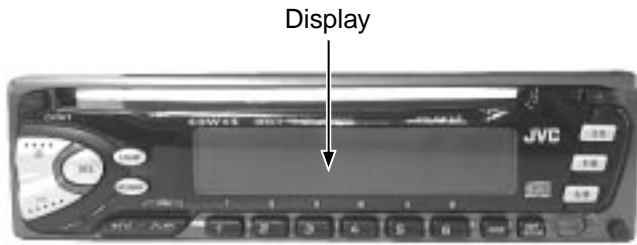

## ■ Main unit

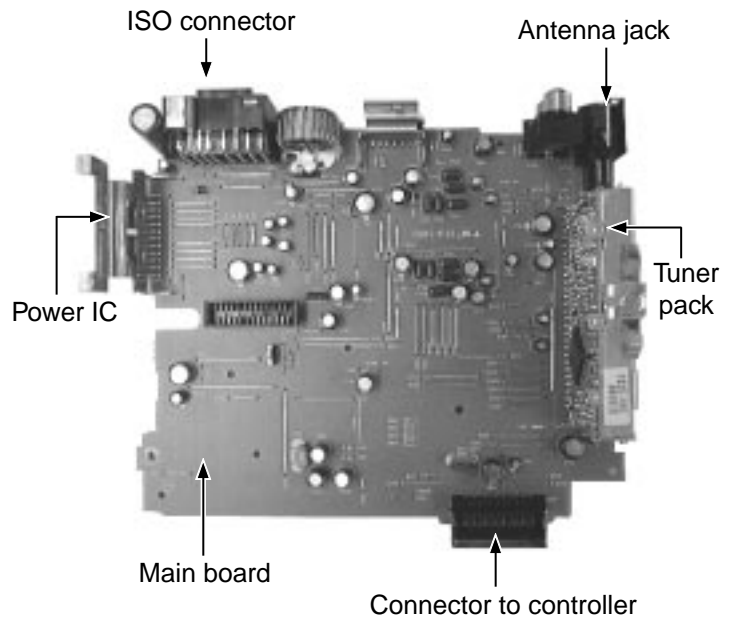
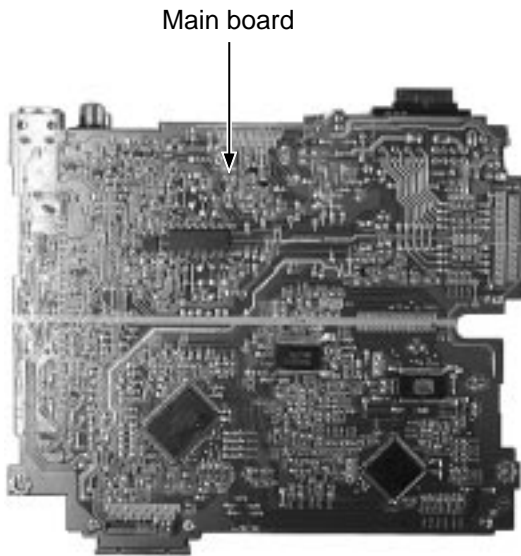

## ■ CD mechanism

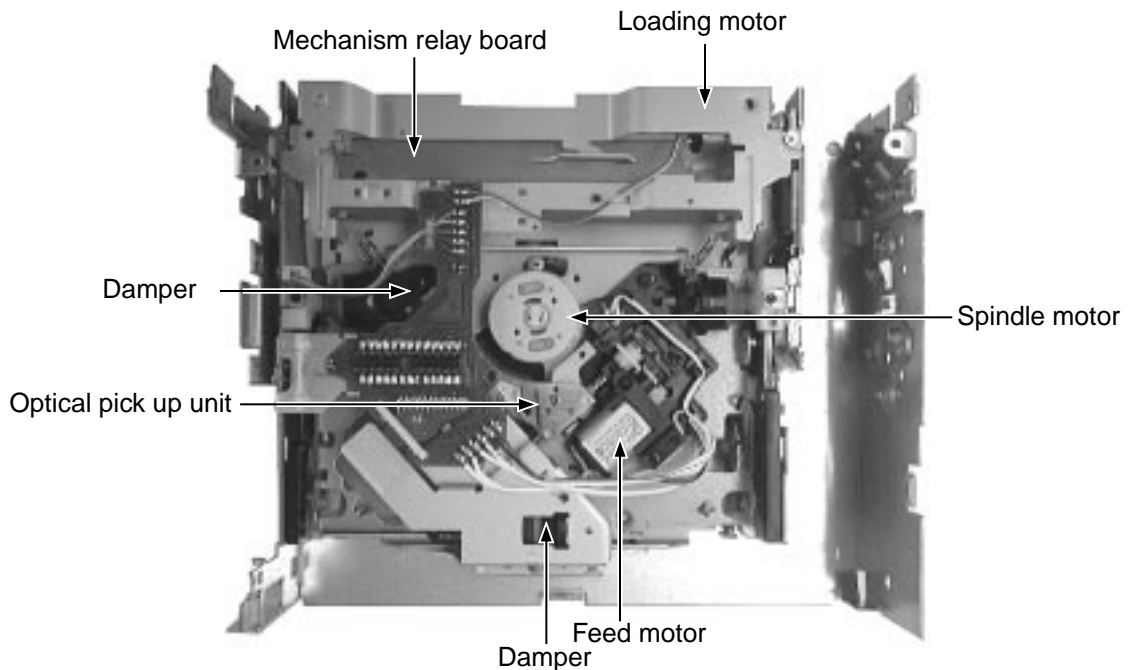

## Disassembly method

### ■ Removing the front panel unit

(See Fig.1)

1. Press the release switch and remove the front panel unit in the direction of the arrow.



Fig.1

### ■ Removing the front chassis (See Fig.2)

1. Insert a screwdriver to the joints a on the side of the front chassis and two joints b on the right side, then detach the front chassis toward the front side.

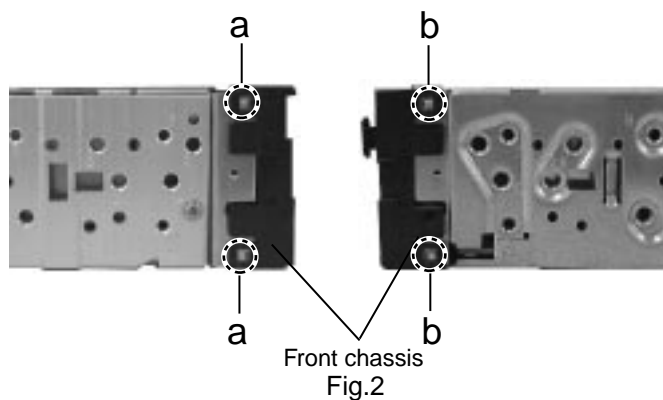

### ■ Removing the heat sink (See Fig.3)

1. Remove the three screws A attaching the heat sink on the left side of the body, and remove the heat sink.

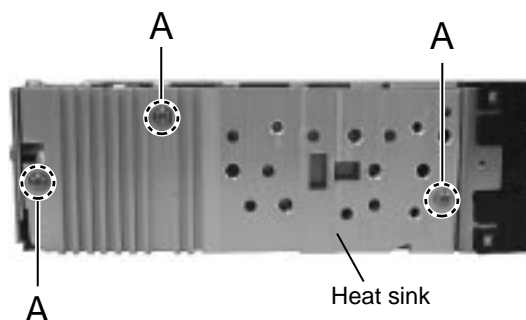

Fig. 3

### ■ Removing the bottom cover (See Fig.4)

1. Turn the body upside down.
2. Insert a screwdriver to the two joints c and two joints d on both sides of the body and the joint e on the back of the body, then detach the bottom cover from the body.

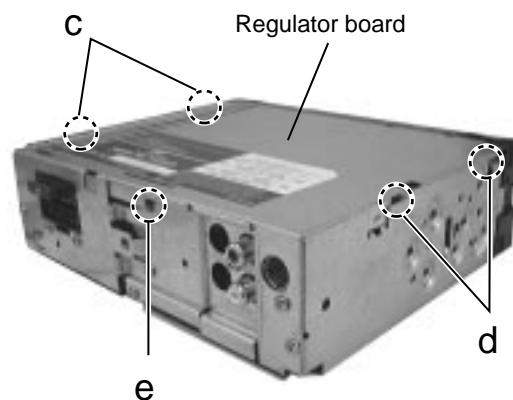

Fig. 4

**■ Removing the main amplifier board  
(See Fig.5 and 6)**

1. Remove the front chassis.
2. Remove the bottom cover.
3. Remove the two screws B attaching the main amplifier board assembly on the bottom of the body.
4. Remove the three screws C attaching the main amplifier board assembly on the back of the body.
5. Disconnect connector CN501 on the main amplifier board assembly from the CD mechanism assembly.

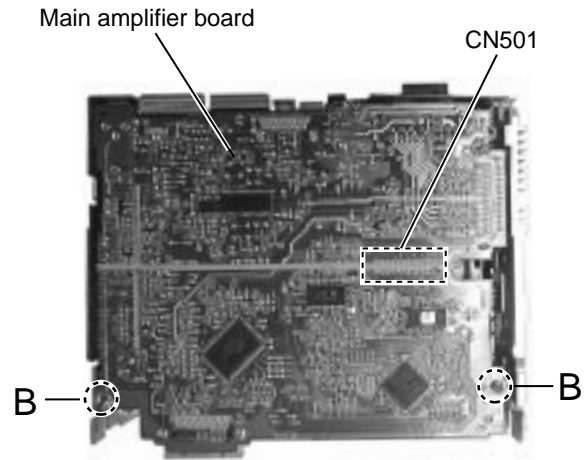

Fig.5

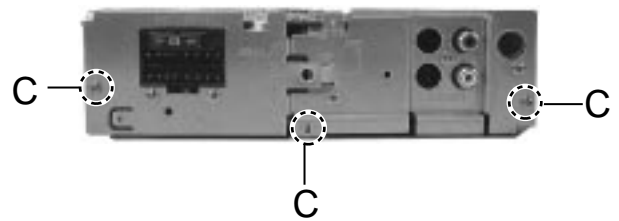

Fig. 6

**■ Removing the CD mechanism assembly  
(See Fig.7)**

1. Remove the front chassis.
2. Remove the bottom cover.
3. Remove the main amplifier board assembly.
4. Remove the three screws D attaching the CD mechanism assembly from the top cover.

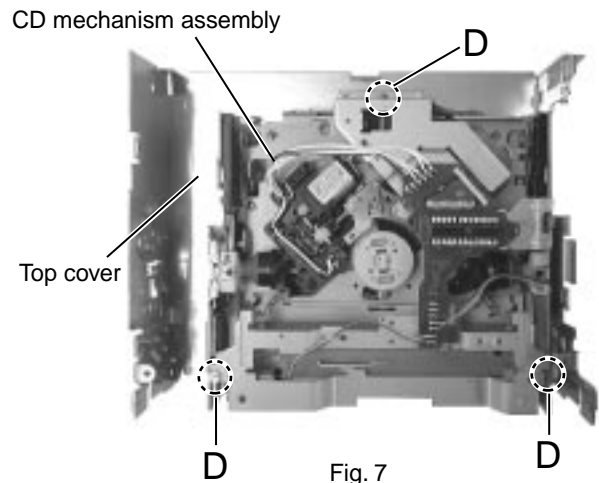

Fig. 7

**■ Removing the control switch board  
(See Fig.8 and 9)**

1. Remove the front chassis.
2. Remove the four screws E attaching the rear cover on the back of the front panel unit.
3. Remove the control switch board from the front panel unit.

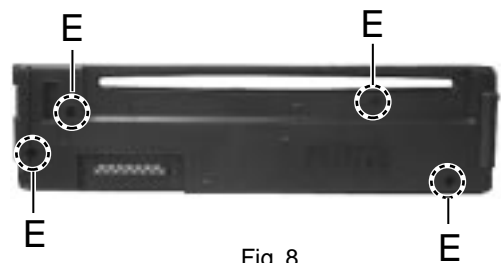

Fig. 8

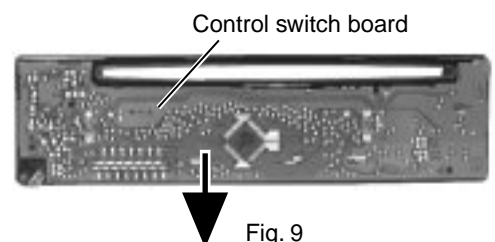

Fig. 9

■ **Removing the CD mechanism control board(See Fig.1 and 2)**

Unsolder the part f and g on the CD mechanism control board.

Remove the stator fixing the CD mechanism control board and the damper bracket (To remove the stator smoothly, pick up the center part).

Remove the screw F attaching the CD mechanism control board.

Remove the CD mechanism control board in the direction of the arrow while releasing it from the two damper bracket slots i and the front bracket slot j.

Disconnect the flexible wire from connector on the pickup unit.

**ATTENTION:** Turn the FD gear in the direction of the arrow to move the entire pickup unit to the appropriate position where the flexible wire of the CD mechanism unit can be disconnected easily (Refer to Fig.2).

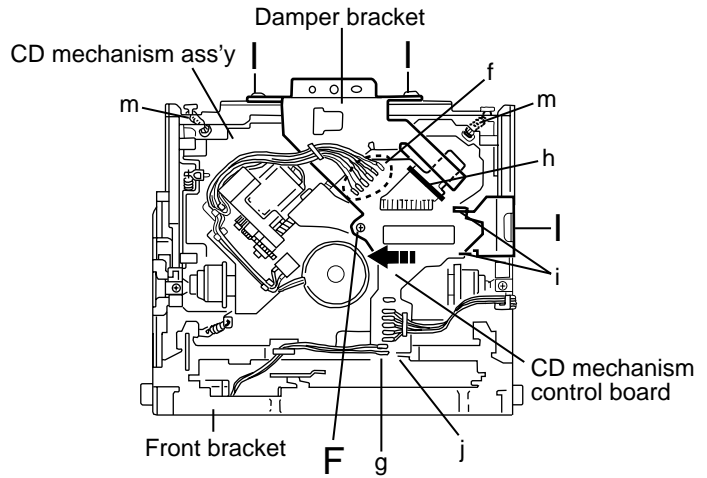

Fig.1

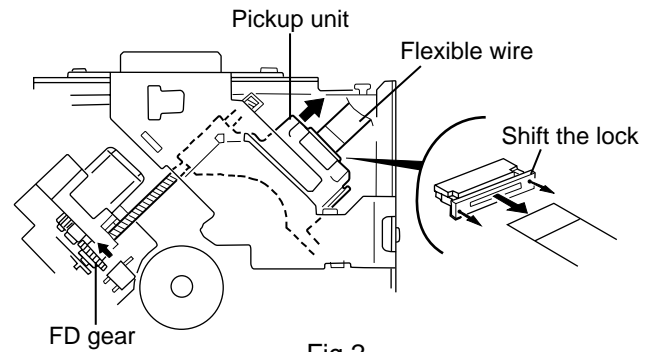

Fig.2

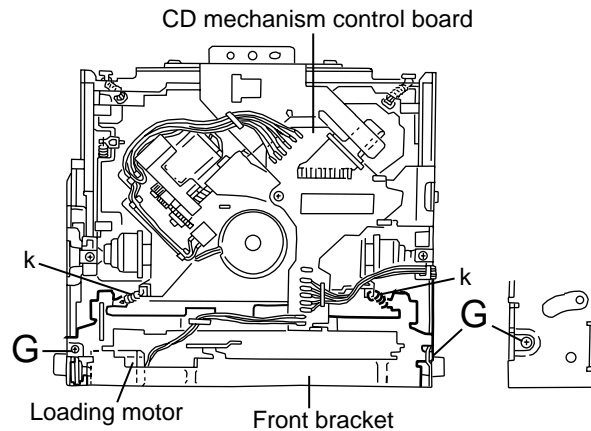

Fig.3

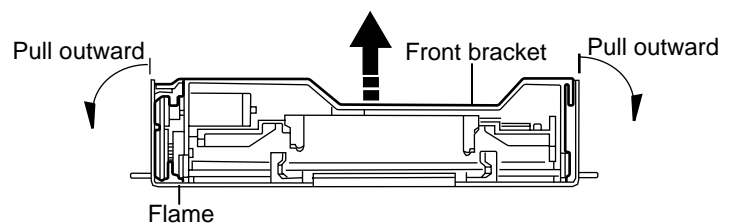

Fig.4

**■ Removing the loading motor**  
**(See Fig.3 to 5)**

• Prior to performing the following procedure, remove the CD mechanism control board.

1. Remove the two springs k attaching the CD mechanism ass'y and the front bracket.
2. Remove the two screws G and the front bracket while pulling the flame outward.
3. Remove the belt and the screw H from the loading motor.

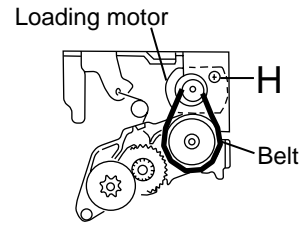

Fig.5

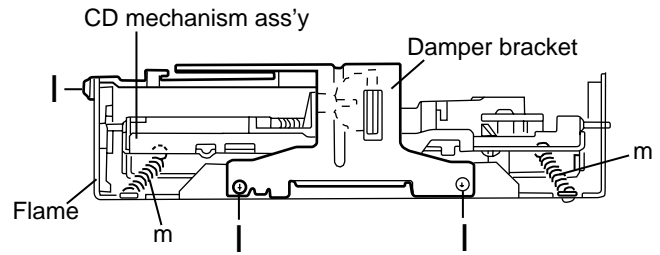

Fig.6

**■ Removing the CD mechanism ass'y**  
**(See Fig.1, 6 to 9)**

• Prior to performing the following procedure, remove the CD mechanism control PWB and the front bracket (loading motor).

1. Remove the three screws I and the damper bracket.
2. Raise the both sides fix arms and move the fix plates in the direction of the arrow to place the four shafts I as shown in Fig.8 and 9.
3. Remove the CD mechanism ass'y and the two springs m attaching the flame.
4. Remove the two screws J and both sides rear damper brackets from the dampers. Detach the CD mechanism ass'y from the left side to the right side.

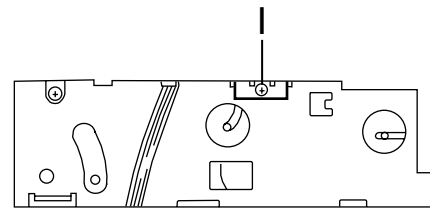

Fig.7

**ATTENTION:** The CD mechanism ass'y can be removed if only the rear damper bracket on the left side is removed.

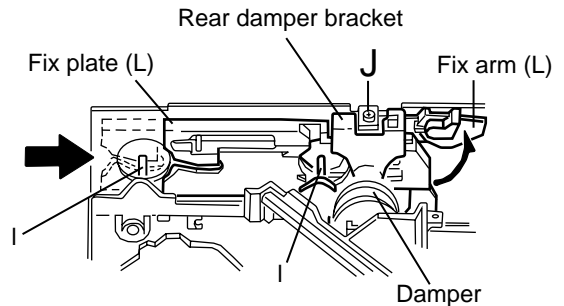

Fig.8

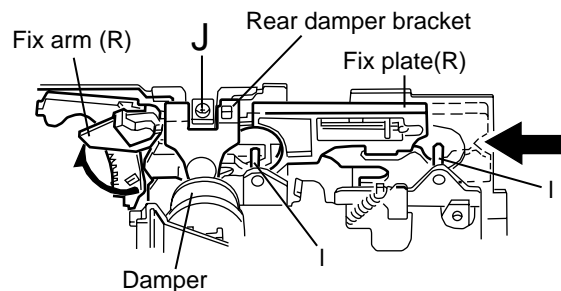

Fig.9

**■ Removing the feed motor ass'y**  
**(See Fig.10)**

- Prior to performing the following procedure, remove the CD mechanism control board, the front bracket (loading motor) and the CD mechanism ass'y.

1. Remove the two screws K and the feed motor ass'y.

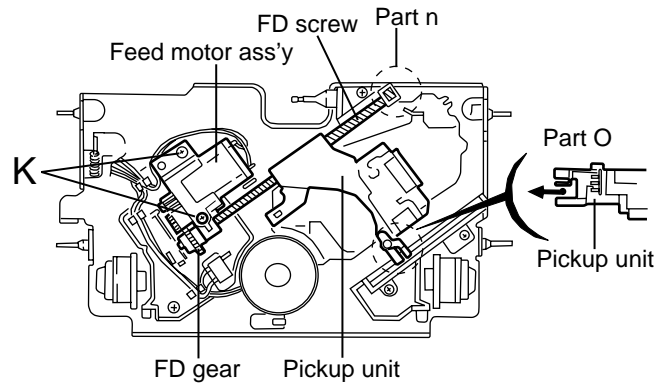

Fig.10

**■ Removing the pickup unit**  
**(See Fig.10 and 11)**

- \*Prior to performing the following procedure, remove the CD mechanism control board, the front bracket (loading motor), the CD mechanism ass'y and the feed motor ass'y.

1. Detach the FD gear part of the pickup unit upward. Then remove the pickup unit while pulling out the part n of the FD screw.

ATTENTION: When reattaching the pickup unit, reattach the part o of the pickup unit, then the part n of the FD screw.

2. Remove the screw L attaching the nut push spring plate and the pickup mount nut from the pickup unit. Pull out the FD screw.

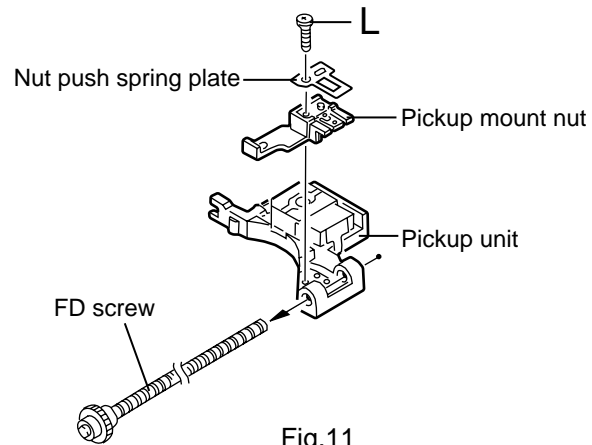

Fig.11

**■ Removing the spindle motor**  
**(See Fig.12 and 13)**

- Prior to performing the following procedure, remove the CD mechanism control board, the front bracket (loading motor), the CD mechanism ass'y and the feed motor ass'y.

1. Turn up the CD mechanism ass'y and remove the two springs p on both sides of the clamber arms. Open the clamber arm upward.

2. Turn the turn table, and remove the two screws M and the spindle motor.

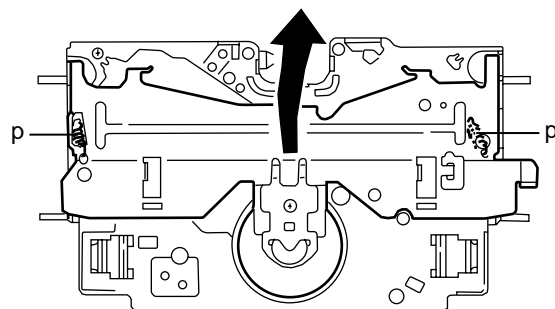

Fig.12

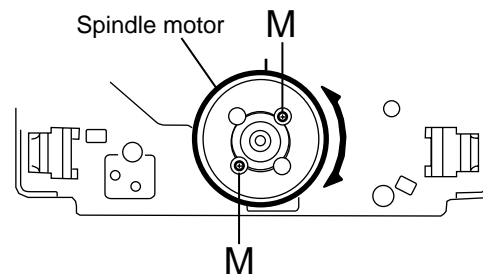

Fig.13



# Adjustment method

## ■ Test instruments required for adjustment

1. Digital oscilloscope (100MHz)
2. AM Standard signal generator
3. FM Standard signal generator
4. Stereo modulator
5. Electric voltmeter
6. Digital tester
7. Tracking offset meter
8. Test Disc JVC :CTS-1000
9. Extension cable for check  
EXTGS004-26P × 1

## ■ Standard volume position

Balance and Bass & Treble volume : Indication "0"

Loudness : OFF

BBE : OFF

Frequency Band

## ■ FM 87.5MHz ~ 108.0MHz

MW 522kHz ~ 1620 kHz

LW 144kHz ~ 279kHz

## ■ Dummy load

Exclusive dummy load should be used for AM, and FM. For FM dummy load, there is a loss of 6dB between SSG output and antenna input. The loss of 6dB need not be considered since direct reading of figures are applied in this working standard.

## ■ Standard measuring conditions

Power supply voltage DC14.4V(10.5~16V)

Load impedance 20Kohm(2 Speakers connection)

Output Level Line out 2.0V (Vol. MAX)

## ■ How to connect the extension cable for adjusting

\* The cardboard is cut in a suitable size.  
uses for the insulation stand of mechanism.

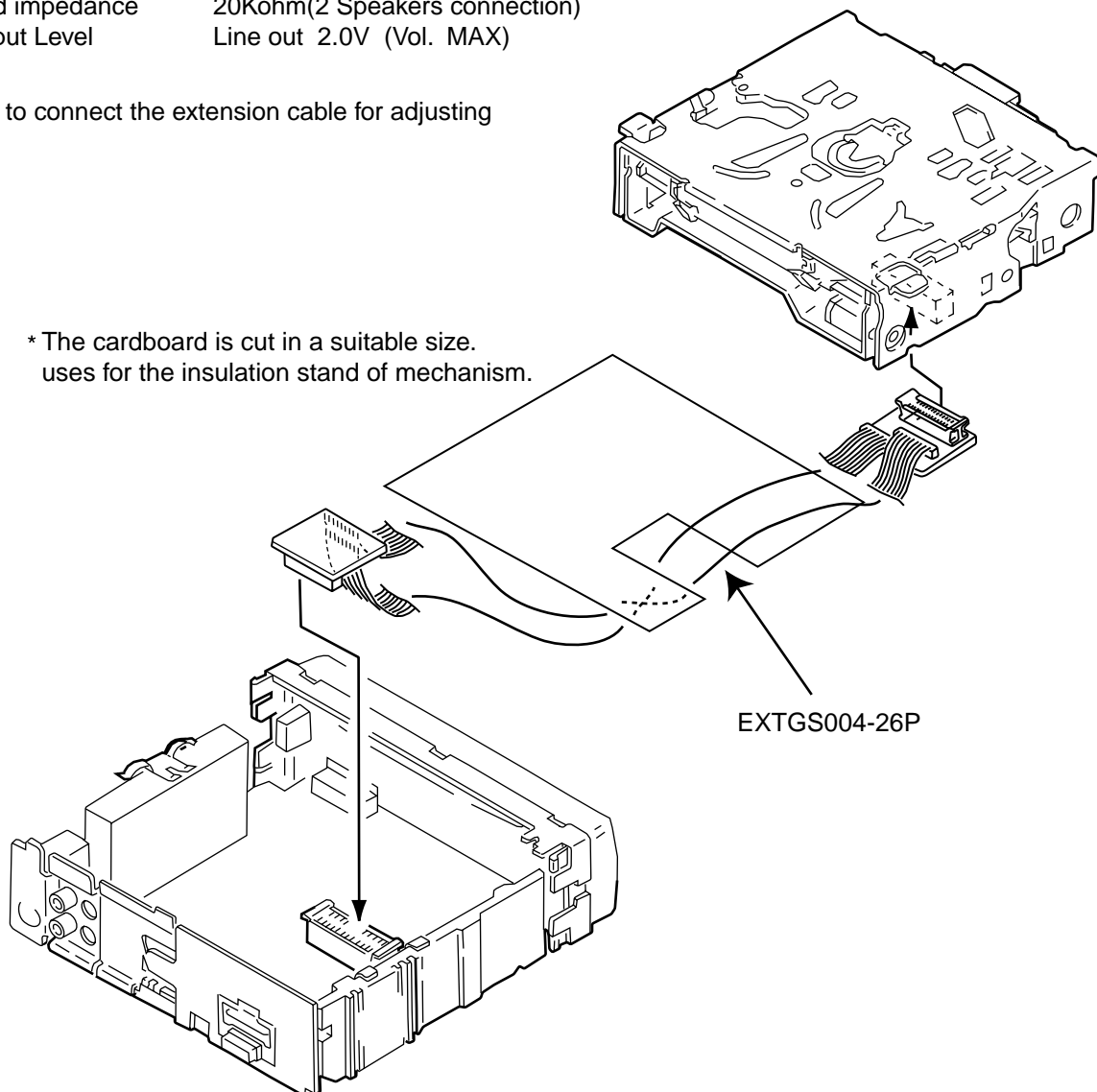

# Flow of functional operation until TOC read

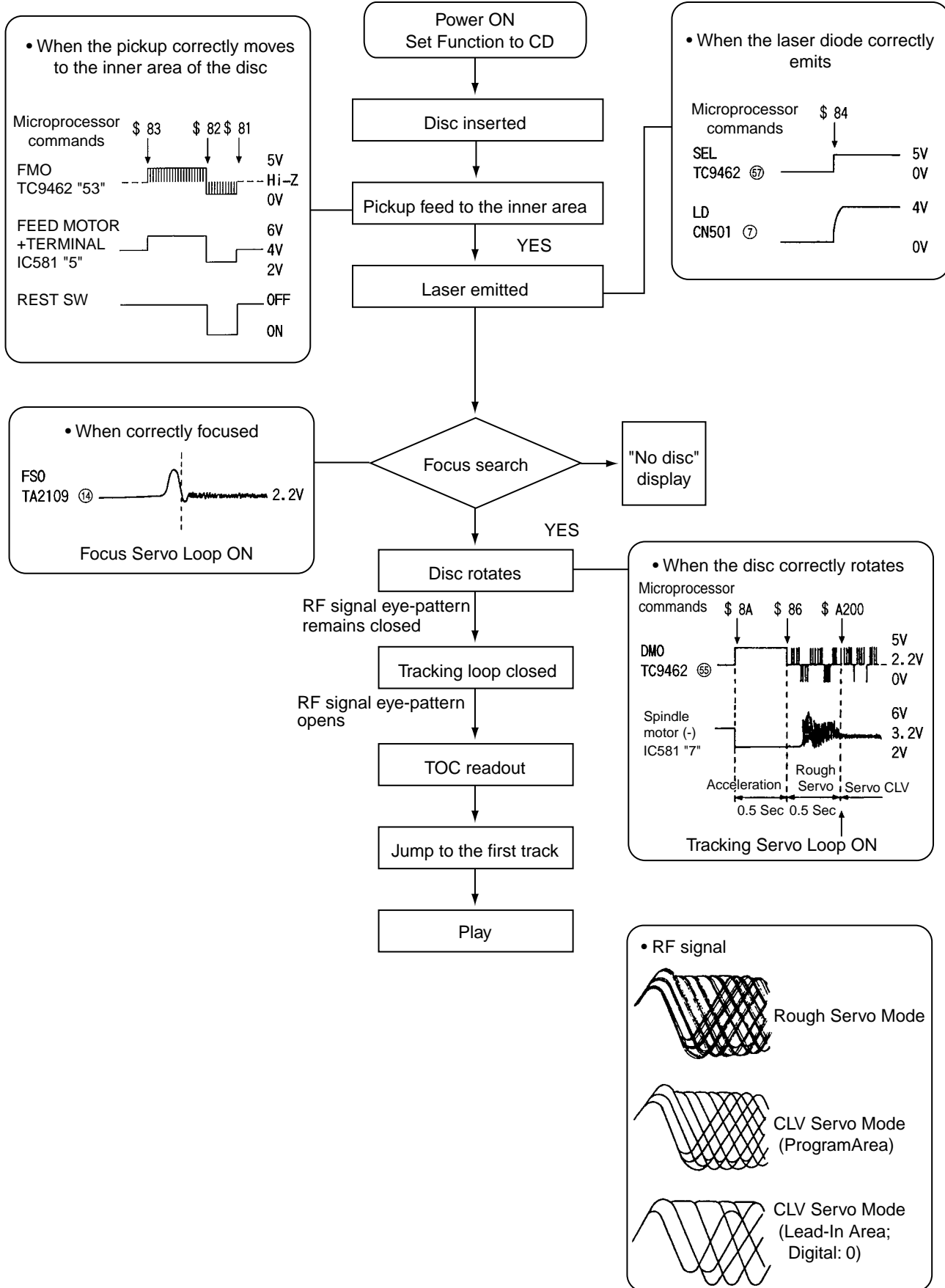

### ■ Feed Section

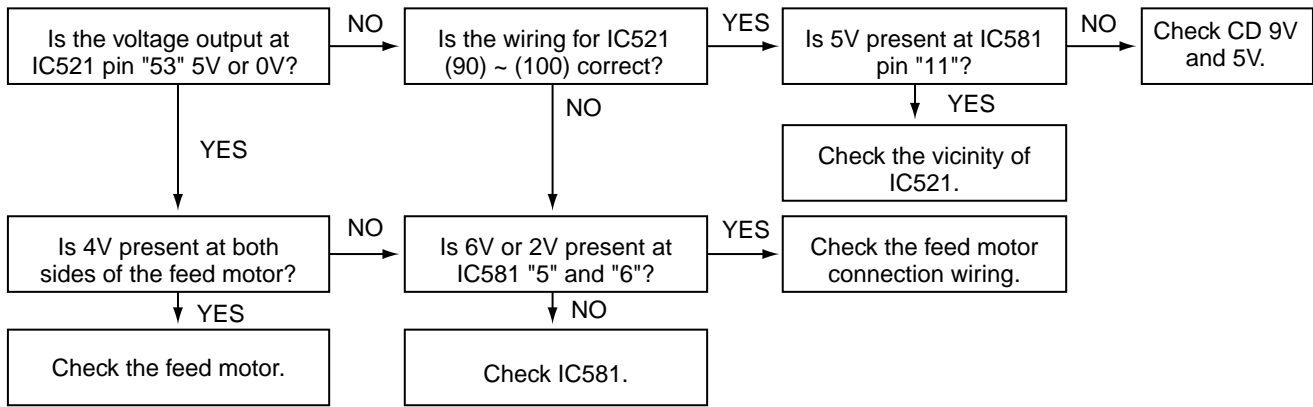

### ■ Focus Section

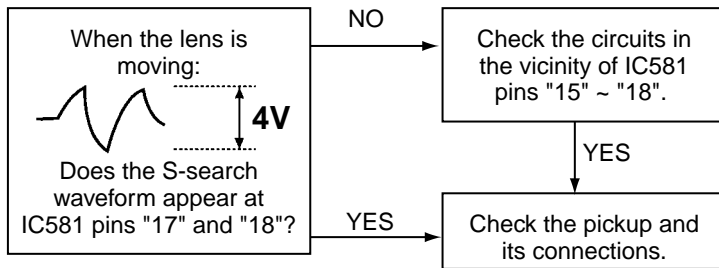

### ■ Spindle Section

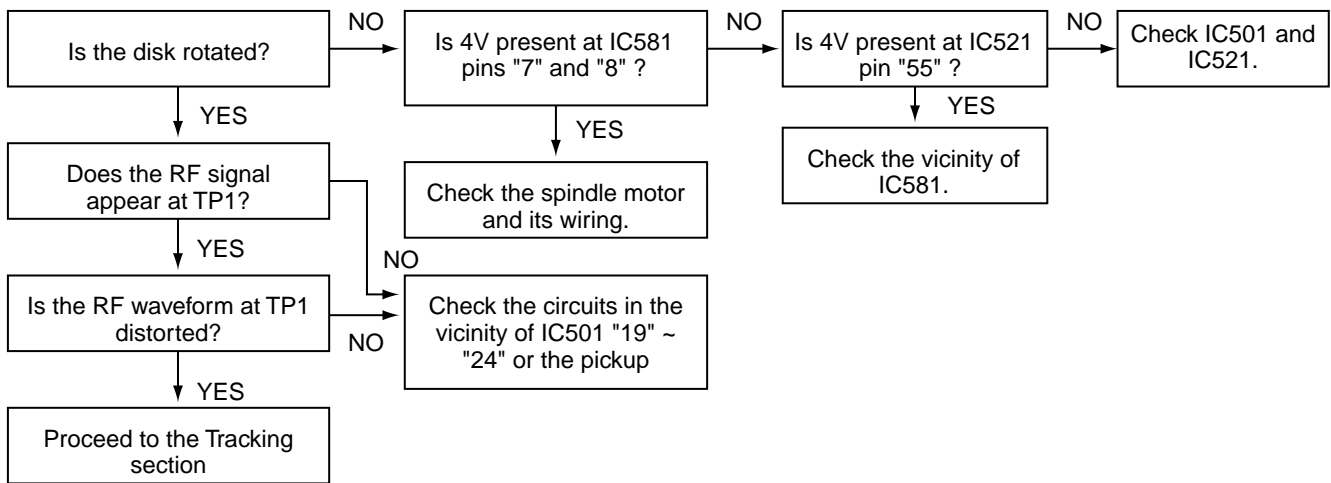

### ■ Tracking Section

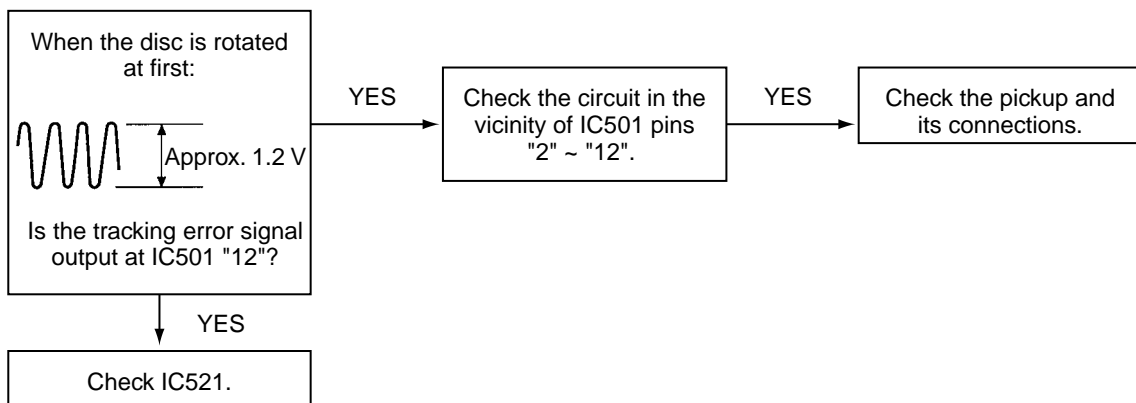

# Maintenance of laser pickup

(1) Cleaning the pick up lens  
 Before you replace the pick up, please try to clean the lens with a alcohol soaked cotton swab.

(2) Life of the laser diode  
 When the life of the laser diode has expired, the following symptoms will appear.  
 (1) The level of RF output (EFM output:amplitude of eye pattern) will be low.

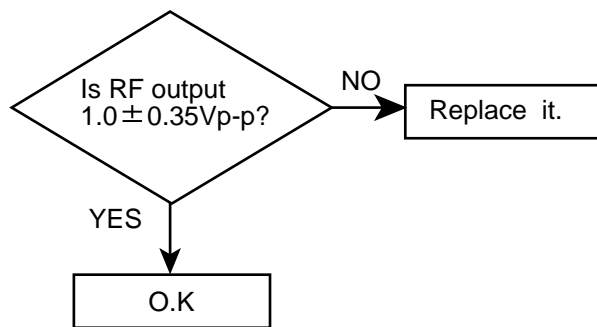

# Replacement of laser pickup

(3) Semi-fixed resistor on the APC PC board  
 The semi-fixed resistor on the APC printed circuit board which is attached to the pickup is used to adjust the laser power. Since this adjustment should be performed to match the characteristics of the whole optical block, do not touch the semi-fixed resistor.  
 If the laser power is lower than the specified value, the laser diode is almost worn out, and the laser pickup should be replaced.  
 If the semi-fixed resistor is adjusted while the pickup is functioning normally, the laser pickup may be damaged due to excessive current.

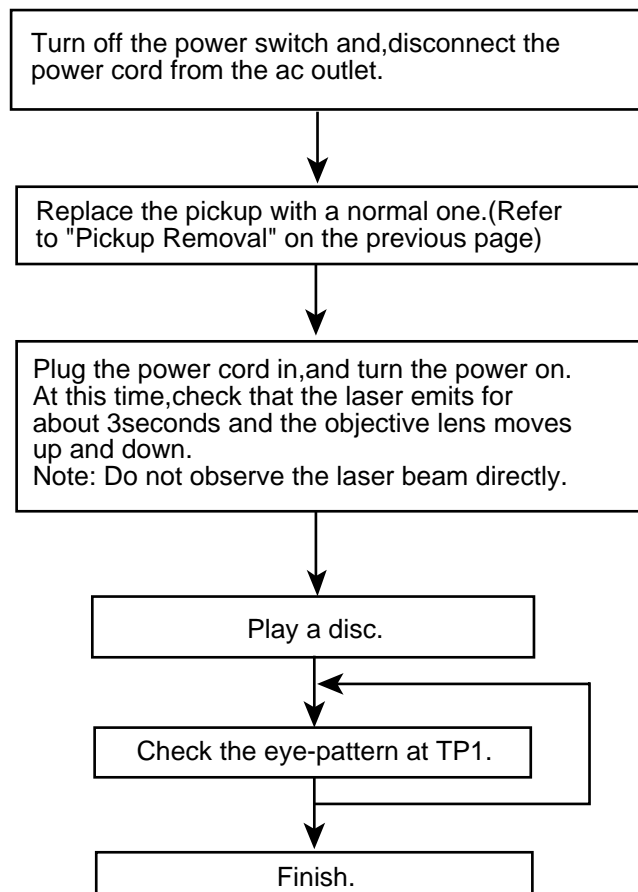

# Description of major ICs

## TEA6320T-X(IC301) : E.volume

1.Terminal Layout

2.Block Diagram

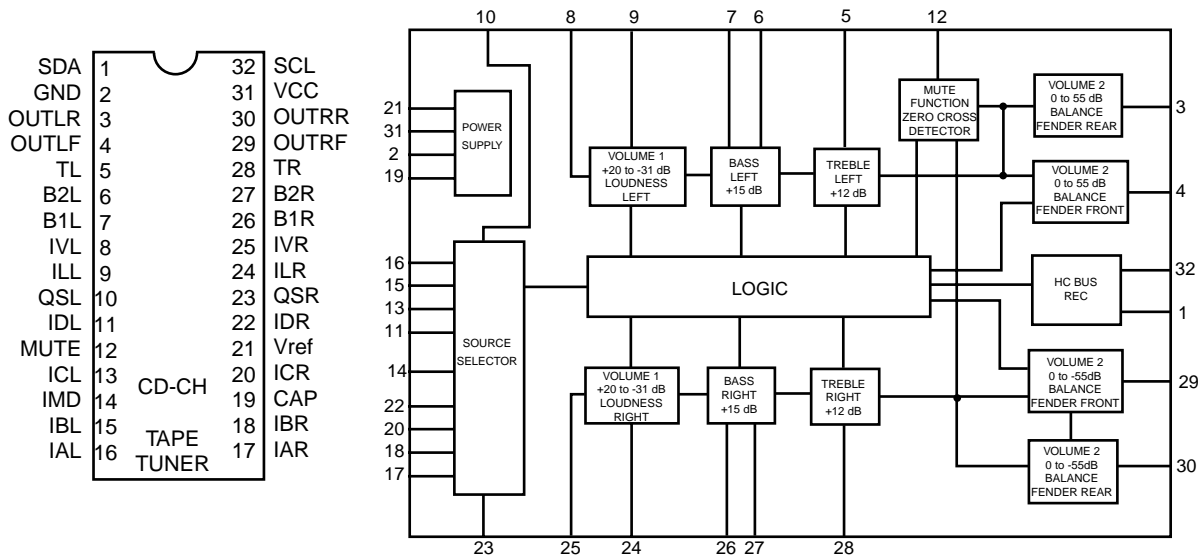

### 3.Pin Functions

Pin No.	Symbol	I/O	Functions	Pin No.	Symbol	I/O	Functions
1	SDA	I/O	Serial data input/output.	17	IAR	I	Input A right source.
2	GND	-	Ground.	18	IBR	I	Input B right source.
3	OUTLR	O	output left rear.	19	CAP	-	Electronic filtering for supply.
4	OUTLF	O	output left front.	20	ICR	I	Input C right source.
5	TL	I	Treble control capacitor left channel or input from an external equalizer.	21	Vref	-	Reference voltage (0.5Vcc)
6	B2L	-	Bass control capacitor leftchannel or output to an external equalizer.	22	IDR	-	Not used
7	B1L	-	Bass control capacitor left channel.	23	QSR	O	Output source selector right channel.
8	IVL	I	Input volume 1. left control part.	24	ILR	I	Input loudness right channel.
9	ILL	I	Input loudness. left control part.	25	IVR	I	Input volume 1. right control part.
10	QSL	O	Output source selector. left channel.	26	B1R	-	Bass control capacitor right channel
11	IDL	-	Not used	27	B2R	O	Bass control capacitor right channel or output to an external equalizer.
12	MUTE	-	Not used	28	TR	I	Treble control capacitor right channel or input from an external equalizer.
13	ICL	I	Input C left source.	29	OUTRF	O	Output right front.
14	IMO	-	Not used	30	OUTRR	O	Output right rear.
15	IBL	I	Input B left source.	31	Vcc	-	Supply voltage.
16	IAL	I	Input A left source.	32	SCL	I	Serial clock input.

■ AN8806SB-W (IC501) : RF&Servo amp.

1.Pin layout

PD	1	36	PDAC
LD	2	35	PDBD
LDON	3	34	PDF
LDP	4	33	PDE
VCC	5	32	PDER
RF-	6	31	PDFR
RF OUT	7	30	TBAL
RF IN	8	29	FBAL
C.AGC	9	28	EF-
ARF	10	27	EF OUT
C.ENV	11	26	TE-
C.EA	12	25	TE OUT
CS BDO	13	24	CROSS
BDO	14	23	TE BPF
CS BRT	15	22	VDET
OFTR	16	21	LD OFF
/NRFDET	17	20	VREF
GND	18	19	ENV

2.Block diagram

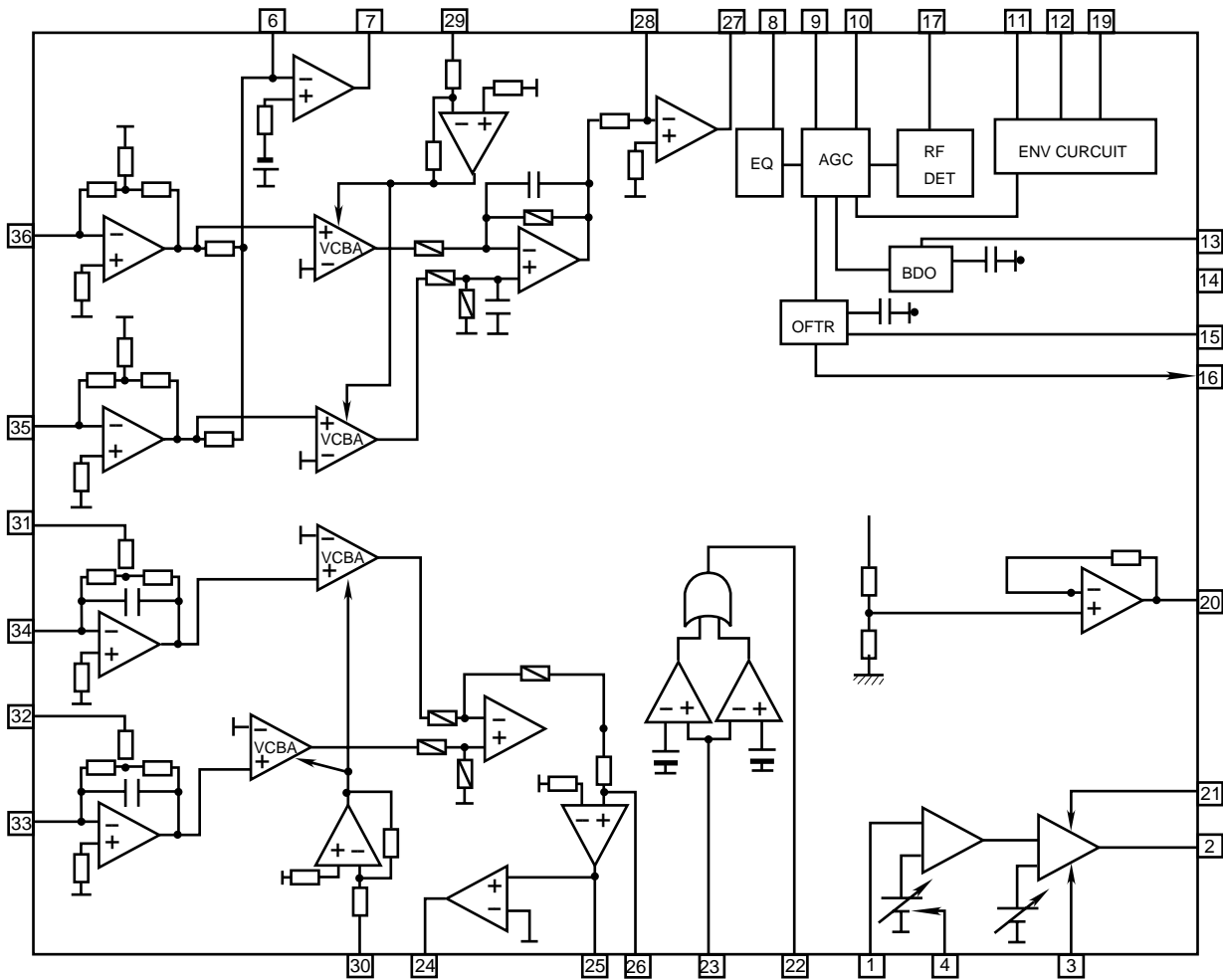

## 3. Pin function

AN8806SB-W

Pin No.	Symbol	I/O	Description
1	PD	I	APC amp input terminal
2	LD	O	APC amp output terminal
3	LD ON	I	APC ON/OFF control terminal
4	LDP	--	Connect to ground
5	VCC	--	Power supply
6	RF-	I	Inverse input pin for RF amp
7	RF OUT	O	RFamp output
8	RF IN	I	RF input
9	C.AGC	I/O	Connecting pin of AGC loop filter
10	ARF	O	RF output
11	C.ENV	I/O	A capacitor is connected to this terminal to detect the envelope of RF signal
12	C.EA	I/O	A capacitor is connected to this terminal to detect the envelope of RF signal
13	CS BDO	I/O	A capacitor is connected to detect the lower envelope of RF signal
14	BDO	O	BDO output pin
15	CS BRT	I/O	A capacitor is connected to detect the lower envelope of RF signal
16	OFTR	O	Of-track status signal output
17	/NRFDET	O	RF detection signal output
18	GND	--	Ground
19	ENV	O	Envelope output
20	VREF	O	Reference voltage output
21	LD OFF	--	Connect to ground
22	VDET	O	Vibration detection signal output
23	TE BPF	I	Input pin of tracking error through BPF
24	CROSS	O	Tracking error cross output
25	TE OUT	O	Tracking error signal output
26	TE-	I	Inverse input pin for tracking error amp
27	FE OUT	O	Output pin of focus error
28	FE-	I	Inverse input pin for focus error amp
29	FBAL	I	Focus balance control
30	TBAL	I	Tracking balance control
31	PDFR	I/O	F I-V amp gain control
32	PDER	I/O	E I-V amp gain control
33	PDF	I	I-V amp input
34	PDE	I	I-V amp input
35	PD BD	I	I-V amp input
36	PD AC	I	I-V amp input

**■ MN35510(IC561):Digital servo & digital signal processor**

1. Terminal Layout

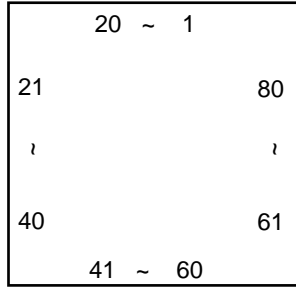

2. Block Diagram

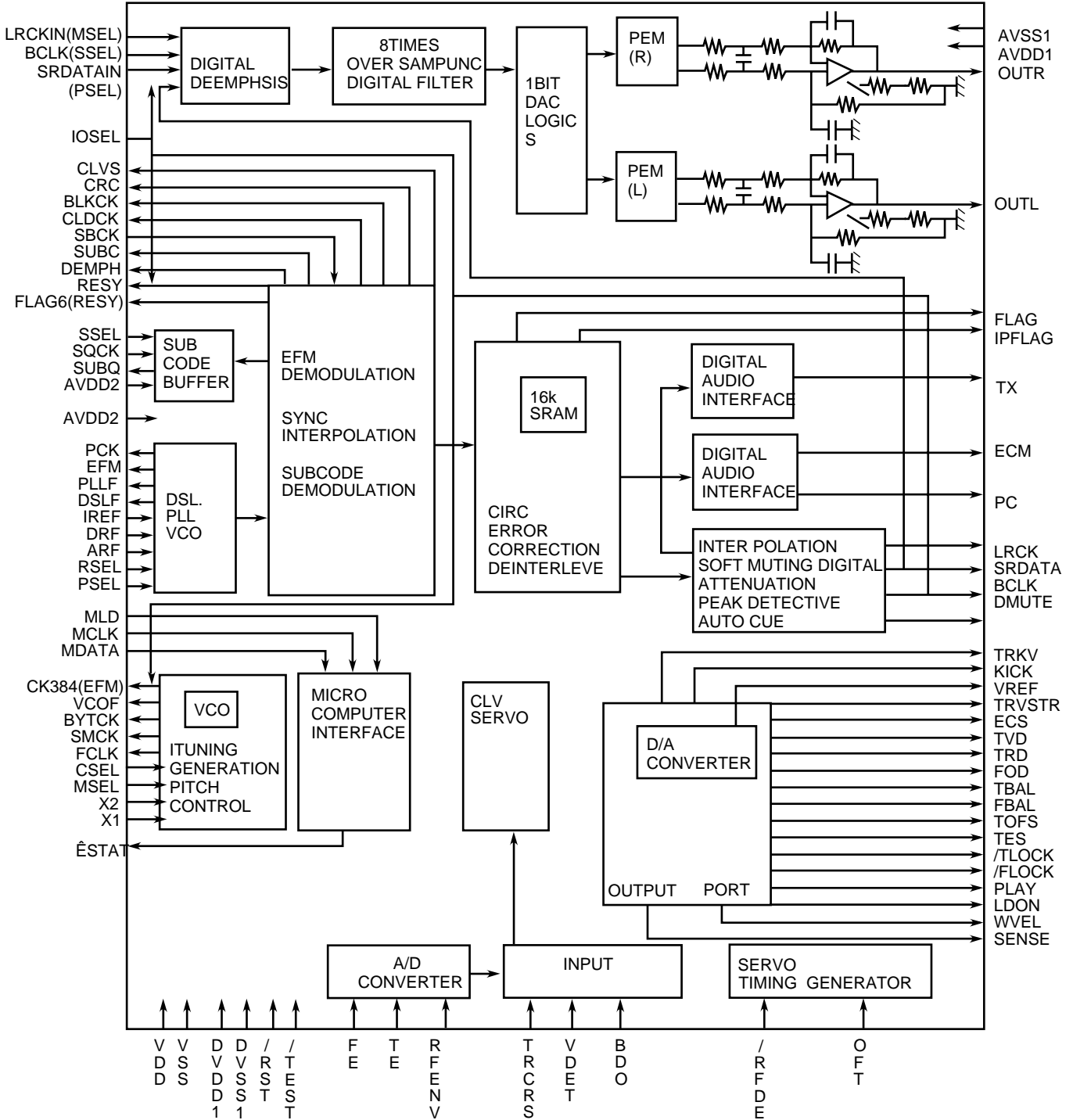



## 3. Description

Pin No.	symbol	I/O	Description	Pin No.	symbol	I/O	Description
1	BCLK	O	Not used	41	TES	O	Tracking error shunt signal output(H:shunt)
2	LRCK	O	Not used	42	PLAY	—	Not used
3	SRDATA	O	Not used	43	WVEL	—	Not used
4	DVDD1	—	Power supply (Digital)	44	ARF	I	RF signal input
5	DVSS1	—	Connected to GND	45	IREF	I	Reference current input pin
6	TX	O	Digital audio interface output	46	DRF	I	Bias pin for DSL
7	MCLK	I	Micom command clock signal input (Data is latched at signal's rising point)	47	DSL F	I/O	Loop filter pin for DSL
8	MDATA	I	Micom command data input	48	PLL F	I/O	Loop filter pin for PLL
9	MLD	I	Micom command load signal input	49	VCOF	—	Not used
10	SENSE	O	Sence signal output	50	AVDD2	—	Power supply(Analog)
11	FLOCK	O	Focus lock signal output Active :Low	51	AVSS2	—	Connected to GND(Analog)
12	TLOCK	O	Tracking lock signal output Active :Low	52	EFM	—	Not used
13	BLKCK	O	sub-code - block - clock signal output	53	PCK	—	Not used
14	SQCK	I	Outside clock for sub-code Q resister input	54	PDO	—	Not used
15	SUBQ	O	Sub-code Q -code output	55	SUBC	—	Not used
16	DMUTE	—	Connected to GND	56	SBCK	—	Not used
17	STATUS	O	Status signal (CRC,CUE,CLVS,TTSTOP,ECLV,SQOK)	57	VSS	—	Connected to GND(for X'tal oscillation circuit)
18	RST	I	Reset signal input (L:Reset)	58	XI	I	Input of 16.9344MHz X'tal oscillation circuit
19	SMCK	—	Not used	59	X2	O	Output of X'tal oscillation circuit
20	PMCK	—	Not used	60	VDD	—	Power supply(for X'tal oscillation circuit)
21	TRV	O	Traverse enforced output	61	BYTCK	—	Not used
22	TVD	O	Traverse drive output	62	CLDCK	—	Not used
23	PC	—	Not used	63	FLAG	—	Not used
24	ECM	O	Spindle motor drive signal (Enforced mode output) 3-State	64	IPPLAG	—	Not used
25	ECS	O	Spindle motor drive signal (Servo error signal output)	65	FLAG	—	Not used
26	KICK	O	Kick pulse output	66	CLVS	—	Not used
27	TRD	O	Tracking drive output	67	CRC	—	Not used
28	FOD	O	Focus drive output	68	DEMPH	—	Not used
29	VREF	I	Reference voltage input pin for D/A output block (TVD,FOD,FBA,TBAL)	69	RESY	—	Not used
30	FBAL	O	Focus Balance adjust signal output	70	IOSEL	—	pull up
31	TBAL	O	Tracking Balance adjust signal output	71	TEST	—	pull up
32	FE	I	Focus error signal input(Analog input)	72	AVDD1	—	Power supply(Digital)
33	TE	I	Tracking error signal input(Analog input)	73	OUT L	O	Lch audio output
34	RF ENV	I	RF envelope signal input(Analog input)	74	AVSS1	—	Connected to GND
35	VDET	I	Vibration detect signal input(H:detect)	75	OUT R	O	Rch audio output
36	OFT	I	Off track signal input(H:off track)	76	RSEL	—	pull up
37	TRCRS	I	Track cross signal input	77	CSEL	—	Connected to GND
38	RFDET	I	RF detect signal input(L:detect)	78	PSEL	—	Connected to GND
39	BDO	I	BDO input pin(L:detect)	79	MSEL	—	Connected to GND
40	LDON	O	Laser ON signal output(H:on)	80	SSEL	—	Pull up

## LA6557-X(IC541) : Servo BTL driver

### 1. Block diagram

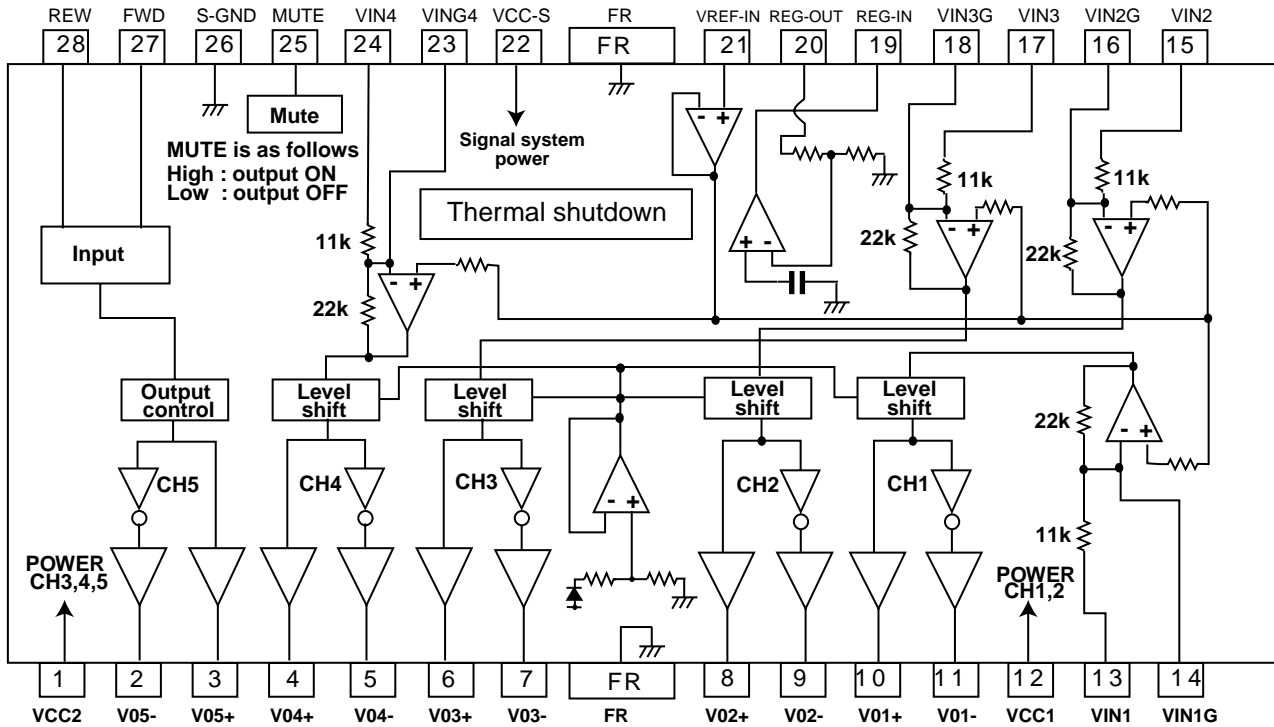

### 2. Pin function

Pin No.	Pin Name	Description
1	VCC2	Power for channels 3, 4, and 5 (VCC1 and VCC-S short-circuited)
2	V05-	Loading output (-)
3	V05+	Loading output (+)
4	V04+	Output pin (+) for channel 4
5	V04-	Output pin (-) for channel 4
6	V03+	Output pin (+) for channel 3
7	V03-	Output pin (-) for channel 3
8	V02+	Output pin (+) for channel 2
9	V02-	Output pin (-) for channel 2
10	V01+	Output pin (+) for channel 1
11	V01-	Output pin (-) for channel 1
12	VCC1	Power for channels 1 and 2 (BTL), (VCC-S and VCC2 short-circuited)
13	VIN1	Input pin for channel 1
14	VIN1G	Input pin for channel 1 (for gain control)
15	VIN2	Input pin for channel 2
16	VIN2G	Input pin for channel 2 (for gain control)
17	VIN3	Input pin for channel 3
18	VIN3G	Input pin for channel 3 (for gain control)
19	REG-IN	Regulator pin (External PNP base)
20	REG-OUT	Regulator pin (External PNP collector)
21	VRFE-IN	Reference voltage input pin
22	VCC-S	Signal system power (VCC1 and VCC2 short-circuited)
23	VIN4G	Input pin for channel 4 (for gain control)
24	VIN4	Input pin for channel 4
25	MUTE	Output ON/OFF, channels 1 to 4 (BTL AMP)
26	S-GND	Signal system GND
27	FWD	5CH(VL0) Output change pin (FWD), Logic input for loading block
28	REV	5CH(VL0) Output change pin (REW), Logic input for loading block

## ■ LC72366-9989 (IC801) : Main micon

### 1. Pin layout

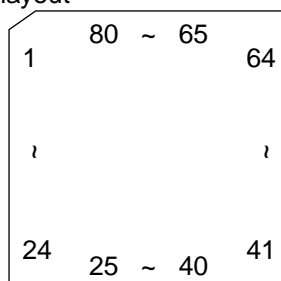

### 2. Pin function

Pin No.	Symbol	Function	Pin No.	Symbol	Function
1	XIN	4.5MHz crystal oscillation	41	CD ON	CD 8V supply on
2	TEST2	Connect to ground	42	RELAY	5V power control
3	J BUS SI	J-BUS signal data input ( to 74HC126 )	43	BBE CTL	No use
4	J BUS SO	J-BUS signal data output ( to 74HC126 )	44	BEEP	No use
5	J BUS SCK	J-BUS output clock signal ( to 74HC126 )	45	SW4	
6	J BUS I/O CONT	J-BUS I/O control	46	SW1	CD mechanism switch 1 for disc in, 8cm disc
7	SUBQ	CD LSI subcode data input	47	SW3	CD mecha. switch 3 for disc present, loading end
8		No use	48	REST	CD pickup rest position
9	SQCK	CD LSI subcode clock	49	JOG0	Rotary encoder input 0
10	RESET	Micon reset pin	50	JOG1	Rotary encoder input 1
11	LCD SI	No use	51	CD SENSE	CD LSI sense signal
12	LCD SO	LCD driver data output	52	STATUS	CD LSI status signal
13	LCDSCK	LCD driver clock signal	53	P.SAVE2	Power save 2 : +B detect
14	LCD CE	LCD driver chip enable port	54	SD/ST	Station detection, Stereo indication
15	FM ILLUMI	No use	55	REMOCON	Remocon input
16	AM ILLUMI	No use	56	J BUS INT	J-BUS interrupt
17	CD ILLUMI	No use	57	BAND	FM/AM band selection
18	DIMMER OUT	No use	58	MONO	FM mono selection
19	LM0	CD loading motor output	59	IFRQ/AGC	During FM auto search, IF request output H after SD
20	LM1	CD loading motor output			detected. During AM auto search, AGC output.
21		No use	60	MUTE	Muting switch
22		No use	61	LEVEL	Level meter input
23		No use	62	S METER	S meter input
24	KS2	No use	63	KEY CHANGE	Connect to ground
25	KS1	No use	64	KEY2	Key 2 data input (AD)
26	KS0	Output for initial setting diode matrix	65	KEY1	Key 1 data input (AD)
27	DETACH	Front panel detect	66	KEY0	Key 0 data input (AD)
28	K2	No use	67	P.SAVE1	Power save 1, ACC power detect
29	K1	Input for initial setting diode matrix	68	SENSE	Voltage sense
30	K0	Input for initial setting diode matrix	69		No use
31	Vdd	5V power supply	70	FM IF COUNT	FM IF counter data input
32	SW2	CD mechanism switch 2 for 12cm disc	71		No use
33	CD LSI RESET	CD LSI reset	72		No use
34	MCLK	CD LSI command clock signal	73	Vdd	5V power supply
35	MDATA	CD LSI command data output	76	AM OSC	No use
36	MLD	CD LSI command load signal	75	FM OSC	FM input frequency
37		No use	76	Vss	Ground
38		No use	77		No use
39	SCL	E.volume clock output	78	EO	PLL error output signal
40	SDA	E.volume data output	79	TEST1	Connect to ground
			80	XOUT	4.5MHz crystal oscillation

■ HA13158A (IC321) : Power amp

1. Pin layout

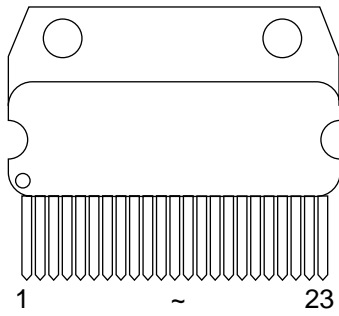

2. Block diagram

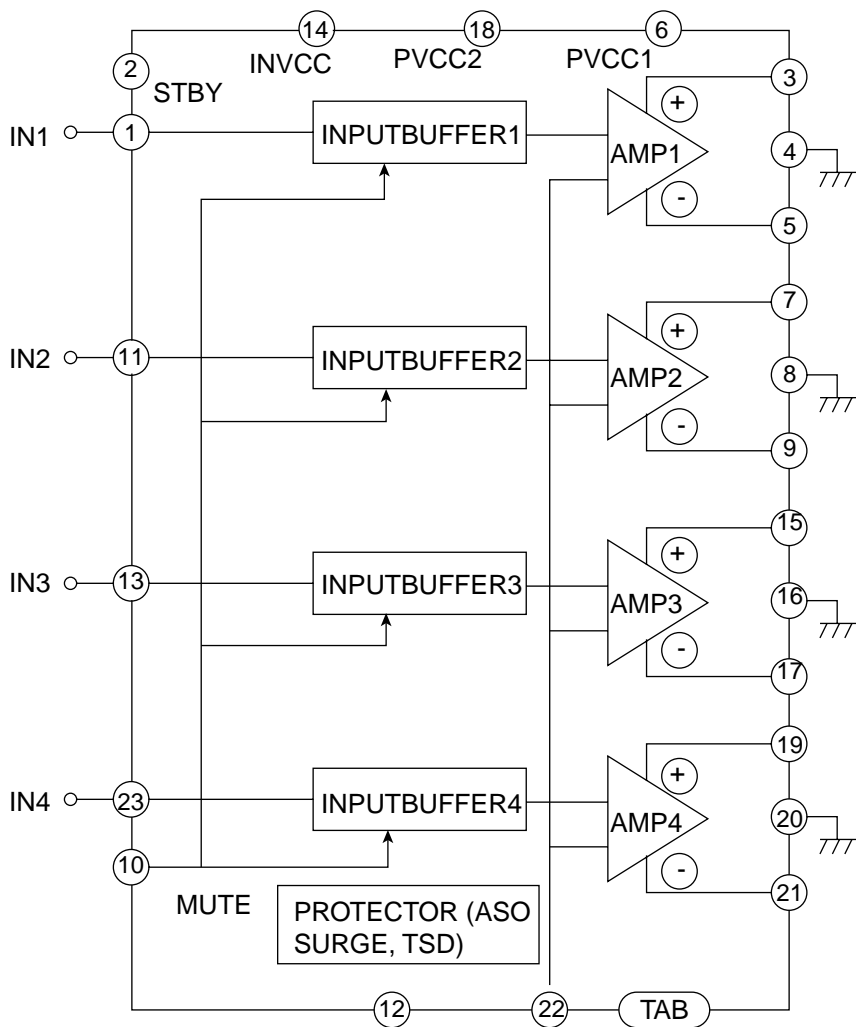

## HA13164(IC901):REGULATOR

### 1.Terminal layout

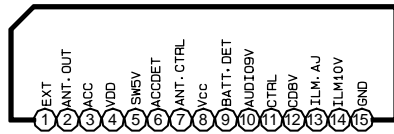

### 2.Block diagram

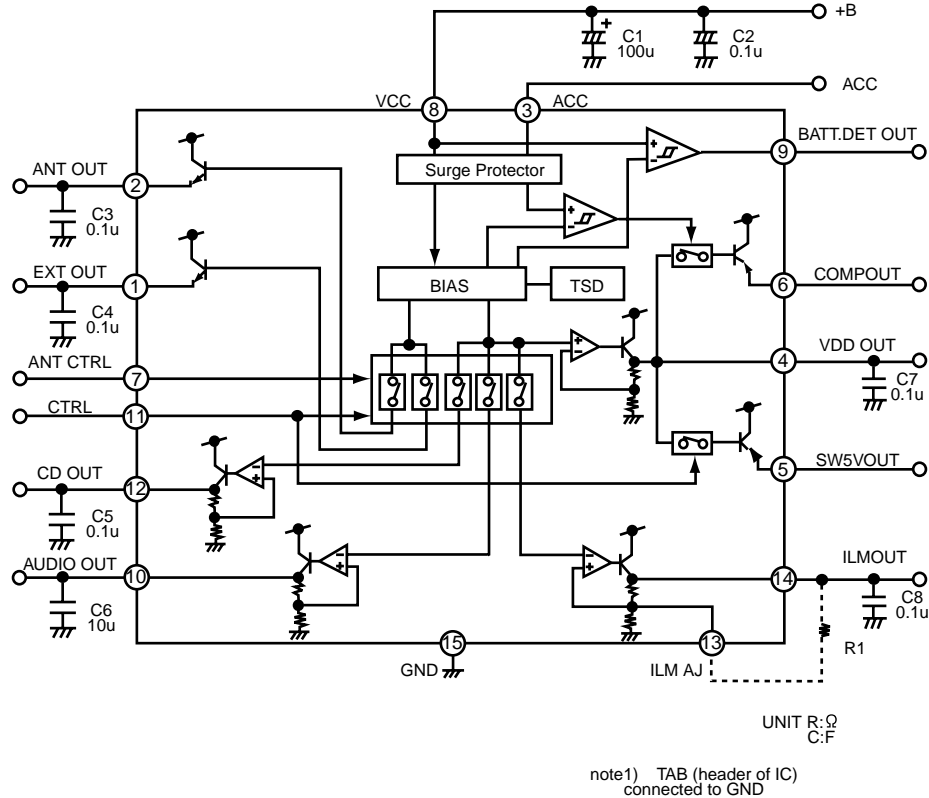

### 3.Pin function

Pin No.	Symbol	Function
1	EXTOUT	Output voltage is VCC-1 V when M or H level applied to CTRL pin.
2	ANTOUT	Output voltage is VCC-1 V when M or H level to CTRL pin and H level to ANT-CTRL.
3	ACCIN	Connected to ACC.
4	VDDOUT	Regular 5.7V.
5	SW5VOUT	Output voltage is 5V when M or H level applies to CTRL pin.
6	COMPOUT	Output for ACC detector.
7	ANT CTRL	L:ANT output OFF , H:ANT output ON
8	VCC	Connected to VCC.
9	BATT DET	Low battery detect.
10	AUDIO OUT	Output voltage is 9V when M or H level applied to CTRL pin.
11	CTRL	L:BIAS OFF, M:BIAS ON, H:CD ON
12	CD OUT	Output voltage is 8V when H level applied to CTRL pin.
13	ILM AJ	Adjustment pin for ILM output voltage.
14	ILM OUT	Output voltage is 10V when M or H level applies to CTRL pin.
15	GND	Connected to GND.

■ LC75823W (IC601) : LCD driver

1. Pin Layout & Symbol

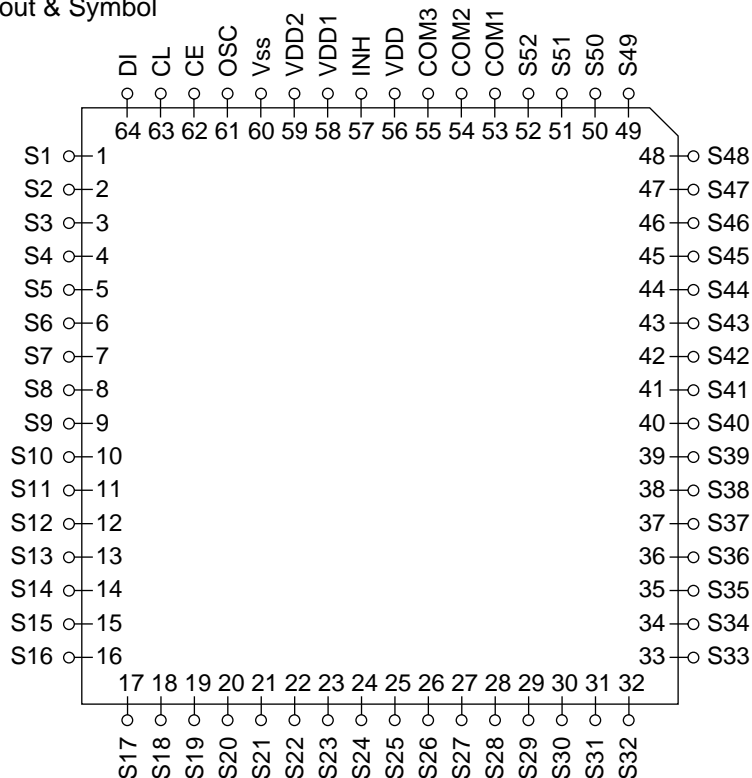

2. Pin Function

Pin No.	Symbol	I/O	Function
1 to 52	S1 to S52	O	Segment output pins used to display data transferred by serial data input.
53 to 55	COM1 to COM3	O	Common driver output pins. The frame frequency is given by : $t_0=(f_{osc}/384)Hz$ .
56	VDD	--	Power supply connection. Provide a voltage of between 4.5 and 6.0V.
57	$\overline{INH}$	I	Display turning off input pin. $\overline{INT}="L"$ (Vss) ----- off (S1 to S52, COM1 to COM3="L" $\overline{INT}="H"$ (VDD)----- on Serial data can be transferred in display off mode.
58	VDD1	I	Used for applying the LCD drive 2/3 bias voltage externally. Must be connected to VDD2 when a 1/2 bias drive scheme is used.
59	VDD2	I	Used for applying the LCD drive 1/3 bias voltage externally. Must be connected to VDD1 when a 1/2 bias drive scheme is used.
60	Vss	--	Power supply connection. Connect to GND.
61	OSC	I/O	Oscillator connection. An oscillalor circuit is formed by connecting an external resistor and capacitor at this pin.
62	CE		Serial data interface connection CE : Chip enable
63	CL	I	to the controller. CL : Sync clock
64	DI		DI : Transfer data

■ BA6218 (IC542) : Motor driver

1. Block diagram

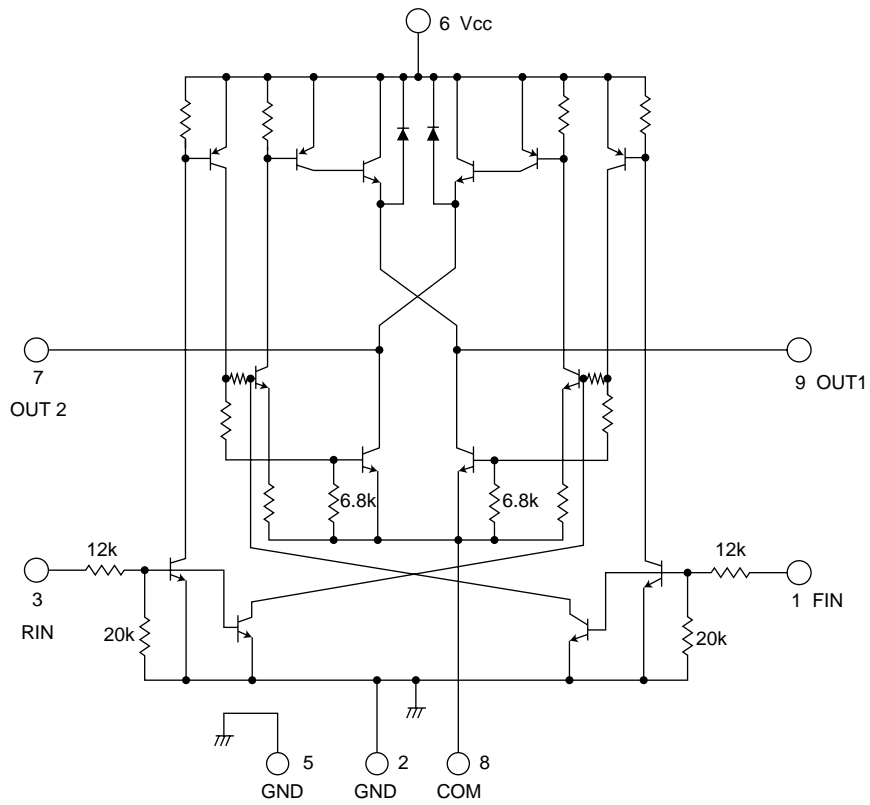

2. Function truth table

3Pin (IN)	1Pin (IN)	7Pin (OUT)	9Pin (OUT)
H	L	H	H
L	H	H	L
H	H	L	L
L	L	OPEN	OPEN

■ NJM4565M-WE (IC151) : Ope. amp

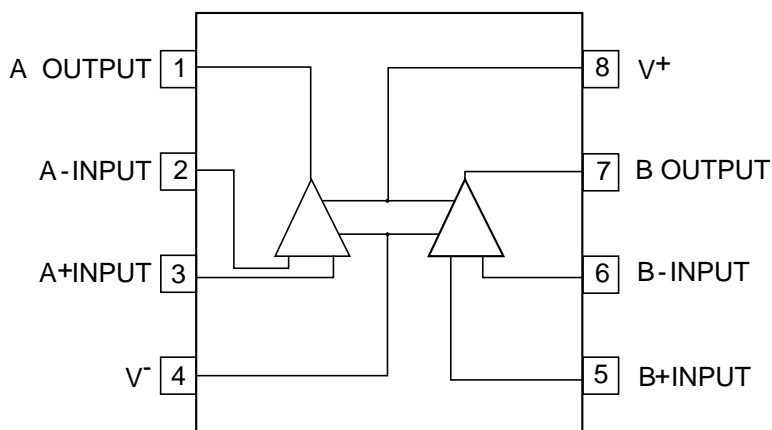



VICTOR COMPANY OF JAPAN, LIMITED

MOBILE ELECTRONICS DIVISION

PERSONAL & MOBILE NETWORK BUSINESS UNIT. 10-1,1Chome,Ohwatari-machi,Maebashi-city,Japan